

### W vortex centrifugal pump

This pump is mainly used as fresh or sea water sanitation, washing, hydrophone tan or drink water supply and so on in marine and off shore industry.

Pump specification in 50Hz motor, 2900rpm.

Model	Capacity (m <sup>3</sup> /h)	Head (m)	NPSHr (m)	Power (kw)
20W-20	0.72	20	3.5	0.75
20W-65	0.72	65	4	2.2
25W-25	1.44	25	4	0.75
25W-70	1.44	70	4.5	3
32W-30	2.88	30	4	1.5
32W-75	2.88	75	5	4
40W-40	5.4	40	5	4
40W-90	5.4	90	6.5	7.5
50W-45	9	45	6	5.5
65W-50	14.4	50	6.5	11

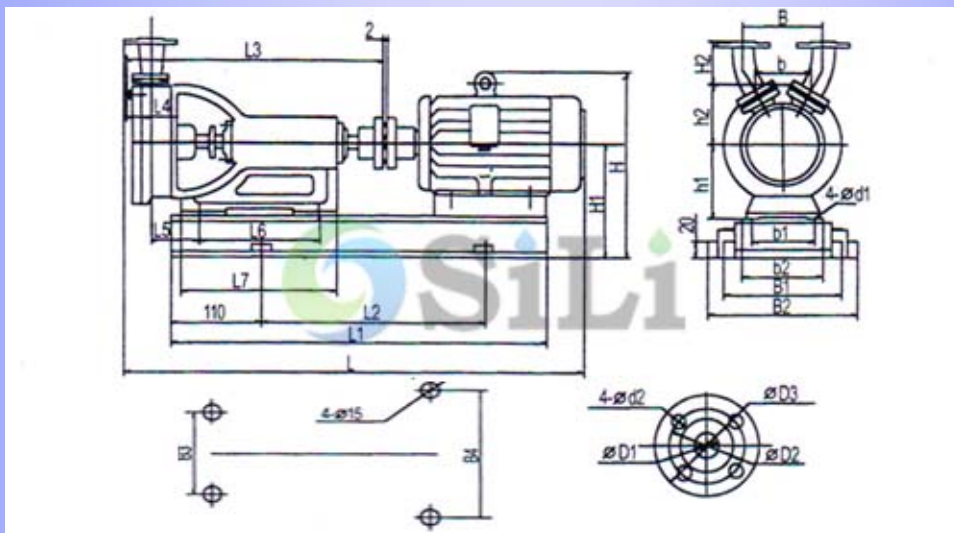

Unit: mm

Model	Installation size													Inlet/outlet flange			
	L	L1	L2	L3	L6	B1	B2	B3	B4	H	H1	B	4-d1	D1	D2	D3	4-d2
20W-20	563	486	278	251	105	230	275	200	245	220	130	110	4-9	20	65	90	4-12
20W-65	605	530	315	270	110	255	295	225	265	245	145	116	4-12	20	75	105	4-14
25W-25	571	483	278	256	105	23	275	200	245	220	130	116	4-10	25	75	100	4-12
25W-70	687	567	339	274	110	255	320	225	290	288	143	121	4-12	25	85	115	4-14
32W-30	621	530	315	279	110	255	295	225	265	245	145	132	4-12	32	90	120	4-14
32W-75	743	612	370	304	115	275	360	245	330	323	170	141	4-12	32	100	135	4-18
40W-40	717	593	355	281	110	255	360	225	330	308	155	135	4-12	40	100	130	4-14
40W-90	825	691	420	308	115	275	390	245	360	383	200	152	4-12	40	110	145	4-18
50W-45	834	615	400	316	115	275	390	245	360	383	200	165	4-12	50	120	160	4-18
65W-50	970	763	481	319	115	290	450	250	410	445	220	185	4-12	65	145	180	4-18

**SILI PUMP, Your reliable one-stop supplier of marine pumps.**

Web: [www.silipump.com](http://www.silipump.com) e-mail: [sales@silipump.com](mailto:sales@silipump.com) (The company reserves the right to make alteration without notice)