

The **SILI CLHB pump** is an ideal pump type, which is popularly used in marine and offshore industry. It is a centrifugal type with volute casing, vertical construction, single stage, single flow, in line and same flanges

- Large capacity range, up to 500m<sup>3</sup>/h.
- Compact structure.
- High efficiency.
- Easy installation/service.
- **Spacer coupling type available**
- **2 poles or 4 poles motor**
- **In-line and same inlet/outlet flanges**

### Design Features

Curved blades to ensure low NPSH-values and high efficiency, close type, statically and dynamically auto balanced.

Shaft supported by radial and thrust ball bearings either greases or self-lubricated, independent bearing body and pump shaft support.

High quality replaceable mechanical shaft seal of an approved brand, tungsten carbon/ceramics. A special mechanical seal for temperature higher than 120 C.

Bronze pump casing&body, impellers and stainless steel shaft as standard for sea water.

Flanges are usually in Chinese GB standard, however other standard flanges in EN(DIN), ANSI, and JIS and so on, can be also provided.

Coupled to 2 or 4 pole quality IEC motor configurations, with high level class and insulation, in both 50Hz and 60Hz, suitable for marine purpose.

When replacing both mechanical seal and impeller, it only needs to remove the elastic clutch and the nut on the lid and, without removing the motor, pump casing and pipeline(for the spacer coupling type only)



### Applications

Within marine industry, the SILI CLHB pumps are suitable as **fresh and seawater cooling pumps, bilge and ballast pumps, fire-fighting, general service pumps, Deck-wash pumps**, and further for transport of slightly aggressive liquids with low viscosity such as diesel and lubricating oils...

#### Capacity range:

10m<sup>3</sup>/h to 500m<sup>3</sup>/h in 50Hz

10m<sup>3</sup>/h to 600m<sup>3</sup>/h in 60HZ

#### Head range:

10m to 120m in 50HZ

10m to 140m in 60HZ

#### Power:

1.5kw to 132kw, 380V/400V/415V/440V, 50Hz/60Hz

#### Speed(motor poles)

1450rpm(4 poles) and 2900rpm(2 poles) in 50HZ

1750rpm(4 poles) and 3500rpm(2 poles) in 60Hz

#### Flange size:

DN25mm(1 inch) to DN250mm(10 inches)

#### Temperature range:

Common type, below 60 C degree, max 80 C degree,  
Special mechanical seal type, below 120 C degree,  
max 140 C degree.

#### Liquid:

Clean sea water, bilge water or fresh water.

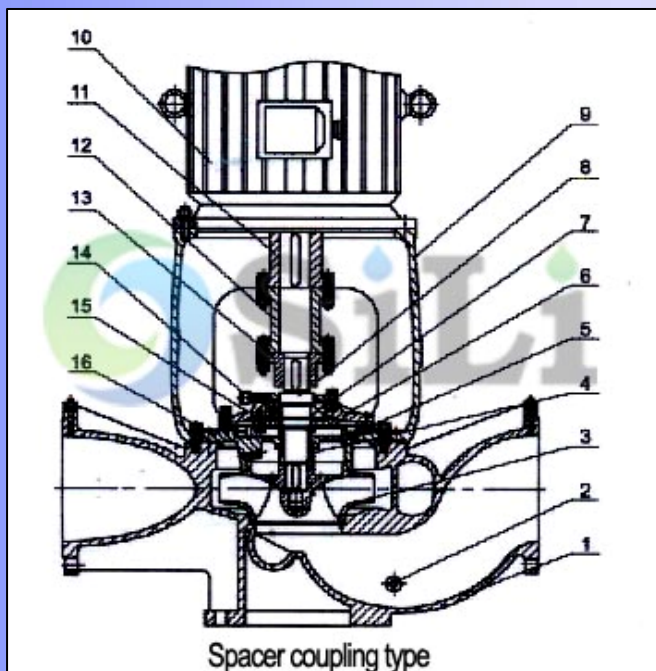
**Material**

Part name	Material	
	Sea water	Fresh water
Cover	Bronze	Cast iron
Casing & body	Bronze	Cast iron
Impeller	Bronze	Bronze
Wear ring	Bronze	Bronze
Shaft seal	Mech. seal	Mech. seal
Shaft	Stainless steel	Stainless steel
Coupling	Cast steel	Cast steel

Bronze: ZcuZn16Si4

Cast iron: HT250(GG25)

Stainless steel: 1Cr18Ni9Ti

**Structure and part item list**

The pump consists of electric motor, shaft, covers, body, impeller and etc. The shaft of pump connects with the impeller to rotate through a coupling(spacer coupling or elastic clutch).

1	Pump body	11	Motor coupling
2	Water drain plug	12	Middle coupling
3	Impeller	13	Pump coupling
4	Mechanical seal	14	Crease cup
5	Exhaust valve	15	Bearing glad
6	Bearing body	16	Pump cover
7	Bearing		
8	Pump shaft		
9	Stand		
10	Motor		

Item 12 is only for the spacer coupling type

**SILI PUMP,**  
**Your reliable one-stop supplier of marine pumps.**

Shanghai SILI PUMP Industry Co., Ltd.

Add: No.128 Jinyuan Road, 201518, Shanghai, China (Jinyuan Industry Area)

Tel: 0086-21-39109967, fax: 0086-21-39109967

Web: www.silipump.com e-mail: sales@silipump.com

(The company reserves the right to make alteration without notice)

