



# CENTRIFUGAL PUMP

---

## ESD



### Application

Cooling Sea Water Pump  
Ballast Pump  
Condenser Cooling Pump

### Feature

Vertical Single-stage Double-suction  
Spacer Coupling Type

**SILI PUMP,**  
**Your reliable one-stop supplier of marine pumps.**

---

Shanghai SILI PUMP Industry Co., Ltd.  
Add: No.128 Jinyuan Road, 201518, Shanghai, China (Jinyuan Industry Area)  
Tel: 0086-21-39109967, fax: 0086-21-39109967  
Web: [www.silipump.com](http://www.silipump.com) e-mail: [sales@silipump.com](mailto:sales@silipump.com)  
(The company reserves the right to make alteration without notice)

<b>I. APPLICATION</b>	.....	1
II. CONSTRUCTION	.....	1
III. NAME & MATERIAL	.....	1
IV. MODEL CODE	.....	2
V. CAPABILITY TABLE (50HZ)	.....	2
VI. CURVE OF CAPABILITY (50HZ)	.....	3
VII. DIMENSION (50HZ)	.....	4
VIII. CAPABILITY TABLE (60HZ)	.....	4
VIII. CURVE OF CAPABILITY (60HZ)	.....	6
IX. DIMENSION (60HZ)	.....	6
X. BACK		

● **APPLICATION**

Cooling Fresh water, Cooling Seawater, Sea Water Service, Bilge & Ballast, Ballast, Fire & General Service.

● **CONSTRUCTION**

The ESD-type is solid casing with spacer coupling, the pump can be disassembled or inspected without removing the motor. There is neither load to the motor bearing nor problem in case of the dry operation because the pump shaft has an independent bearing. The pump can be used as an automatic self-priming pump by fitting an air ejector.

● **NAME & MATERIAL**

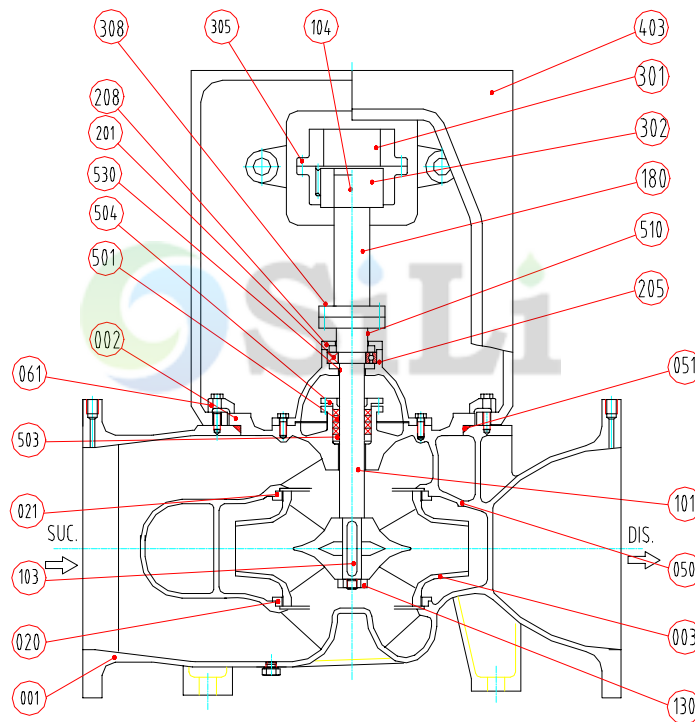

serial number	name	number	MATERIAL	
			seawater	freshwater
001	casing	1	bronze	cast iron
002	casing cover	1	bronze	cast iron
003	impeller	1	bronze	bronze
020	casing ring	1	bronze	bronze
021	casing ring	1	bronze	bronze
050	o-ring	1	rubber	rubber
051	o-ring	1	rubber	rubber
061	fixing flatter	8	ductile cast iron	ductile cast iron
101	shaft	1	stainless steel	stainless steel
103	impeller key	2	stainless steel	stainless steel
104	coupling key	1	carbon steel	carbon steel
130	hub cup	1	stainless steel	stainless steel
180	coupling space	1	carbon steel	carbon steel

201	bear	1	bearing steel	bearing steel
205	bear housing	1	cast iron	cast iron
208	bear cover	1	cast iron	cast iron
301	coupling	1	carbon steel	carbon steel
302	coupling	1	carbon steel	carbon steel
305	coupling bolt & nut		carbon steel	carbon steel
308	bolt	8	carbon steel	carbon steel
403	frame	1	cast iron	cast iron
501	gland packing	4 (1)		
503	lantern ring	1	bronze	bronze
504	gland	1	bronze	bronze
510	V-ring	1	rubber	rubber
530	oil seal	1	rubber	rubber

● MODEL CODE

ESDE-350MC-C55 × 6

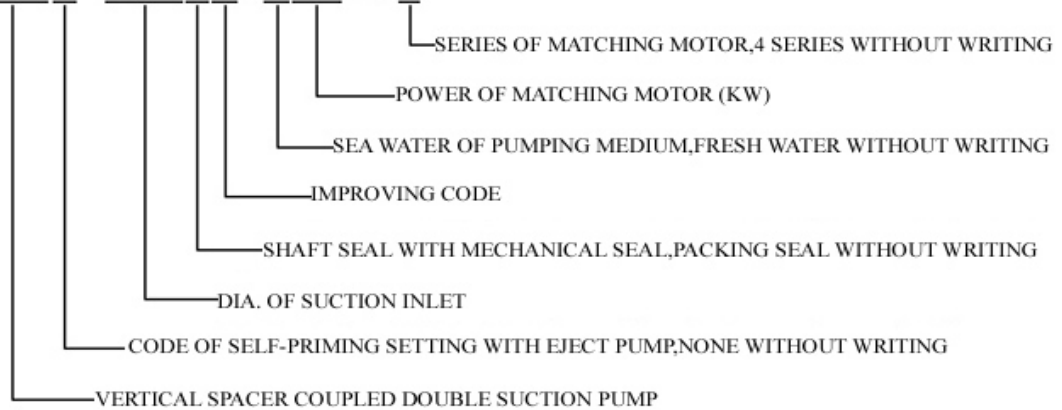

● THE CAPABILITY TABLE OF THE ESD-TYPE WITH 50Hz

TYPE		CAPABILITY		TOTAL HEAD (m)	SPEED (rpm)	POWER (KW)		MOTOR-TYPE
		M <sup>3</sup> /h	l/min			SHAFT POWER	MATCHING POWER	
ESD-300C	-55	360	6000	26.50	1500	38.78	55	YH250M-4V1
		600	10000	22.00		49.93		
		720	12000	18.00		51.15		
	-37	360	6000	21.00	1500	28.35	37	YH225S-4V1
		600	10000	16.00		34.17		
		720	12000	12.00		35.36		
	-30	288	4800	20.00	1500	22.41	30	YH200L-4V1
		480	8000	16.00		26.53		
		576	9600	13.00		27.49		
	-22	276	4600	16.00	1500	16.37	22	YH180L-4V1
		460	7667	12.00		19.73		
		552	9200	9.00		20.89		
ESD-350C	-90	500	8333	28.50	1500	64.68	90	YH280M-4V1
		830	13833	25.00		78.48		
		1000	16667	21.00		80.43		
	-75	480	8000	25.50	1500	52.85	75	YH280S-4V1
		800	13333	21.00		65.36		

	-55	960	16000	16.50	1500	67.39	55	YH250M-4V1				
		420	7000	24.00		42.15						
		700	11667	18.50		48.98						
		840	14000	15.00		52.00						
	-45	330	5500	21.00	1500	32.53	45		YH225M-4V1			
		550	9167	17.50		37.45						
		660	11000	15.00		41.48						
ESD-350C	-45*6	360	6000	18.00	1000	29.41	45	YH280S-6V1				
		600	10000	16.00		35.81						
		720	12000	14.50		40.62						
	-37*6	420	7000	15.80	1000	31.70	37			YH250M-6V1		
		700	11667	12.50		33.10						
		840	14000	10.00		34.85						
	-30*6	330	5500	12.50	1000	20.06	30		YH225M-6V1			
		550	9167	10.00		22.40						
		660	11000	8.50		25.89						
	ESD-400C	-132*6	690	11500	27.00	1000	84.59				132	YH315L2-6V1
			1150	19167	25.00		101.68					
			1380	23000	23.50		116.21					
-90*6		600	10000	22.00	1000	61.98	90	YH315M-6V1				
		1000	16667	19.00		69.92						
		1200	20000	17.00		73.10						
-75*6		480	8000	18.00	1000	41.80	75			YH315S-6V1		
		800	13333	16.00		52.03						
		960	16000	14.50		54.15						

● **THE CURVE OF CAPABILITY**

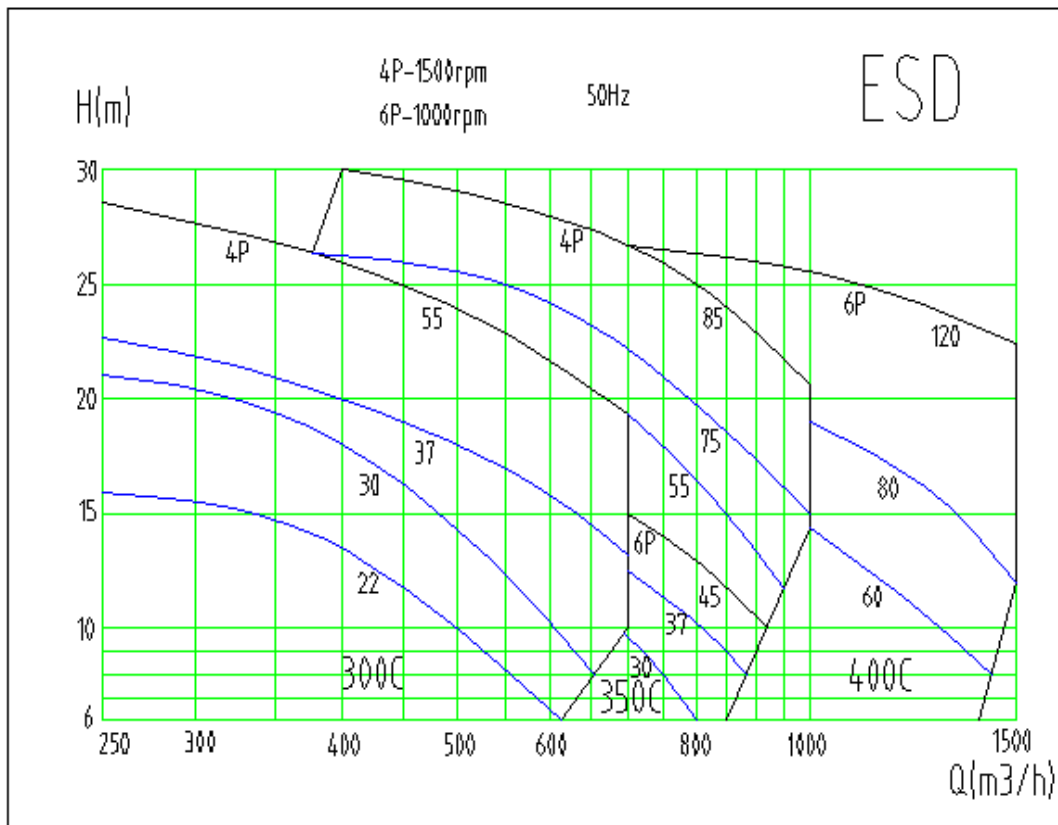

● DIMENSION

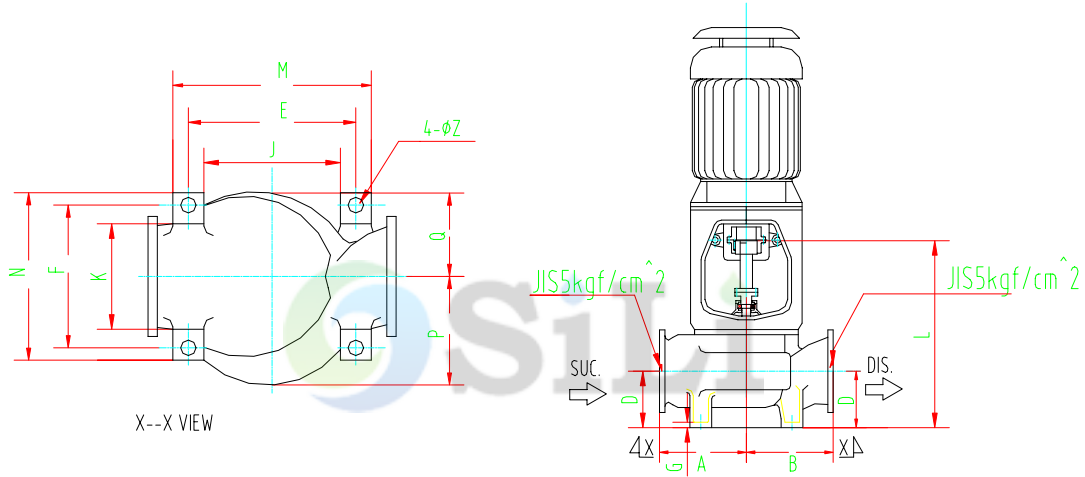

TYPE	SUC	DIS	A	B	C	D	E	F	G	J	K	L	M	N	P	Q	Z
ESD-300C	300	300	400	400	260	260	540	460	25	440	340	1210	640	540	365	270	28
ESD-350C	350	350	500	520	290	290	600	600	30	480	440	1495	720	680	380	340	35
ESD-400C	400	400	550	550	300	300	640	640	30	520	480	1460	760	720	490	360	35

● THE CAPABILITY TABLE OF THE ESD-TYPE WITH 60Hz

TYPE		CAPACITY		TOATL HEAD (m)	SPEED (rpm)	POWER (KW)		MOTOR-TYPE
		M <sup>3</sup> /h	l/min			SHAFT POWER	MATCHING POWER	
ESD-300C	-90	470	7833	37.00	1800	67.65	90	YH280M-4V1
		780	13000	30.00		81.70		
		936	15600	22.50		81.93		
	-90	480	8000	34.50	1800	62.52	90	YH280M-4V1
		800	13333	26.00		72.63		
		960	16000	18.50		74.41		
	-75	420	7000	30.00	1800	54.46	75	YH280S-4V1
		700	11667	24.00		62.71		
		840	14000	20.00		63.17		
	-55	300	5000	30.00	1800	49.02	55	YH250M-4V1
		500	8333	26.00		51.32		
		600	10000	23.00		52.20		
	-45	330	5500	27.00	1800	39.87	45	YH225M-4V1
		550	9167	22.00		42.82		
		660	11000	18.00		43.14		
-37	330	5500	23.00	1800	32.79	37	YH225S-4V1	
	550	9167	18.00		35.17			
	660	11000	13.50		35.82			

ESD-350C	-160	720	12000	41.00	1800	116.51	160	YH315L1-6V1
		1200	20000	30.00		130.72		
		1400	24000	22.00		131.35		
	-132	630	10500	36.50	1800	101.02	132	YH315M-6V1
		1050	17500	27.50		104.81		
		1260	21000	18.50		105.50		
	-110	450	7500	36.00	1800	67.87	110	YH315S-4V1
		750	12500	30.00		87.50		
		900	15000	25.00		92.36		
	-90	540	9000	32.00	1800	72.40	90	YH280M-4V1
		900	15000	22.50		78.73		
		1080	18000	15.00		80.21		
-75	390	6500	30.00	1800	61.75	75	YH280S-4V1	
	650	10833	25.00		63.22			
	780	13000	21.50		70.26			
ESD-350C	-75*6	540	9000	25.00	1200	51.06	75	YH315S-6V1
		900	15000	20.00		65.36		
		1080	18000	16.00		67.23		
	-75*6	435	7250	23.50	1200	42.83	75	YH315S-6V1
		725	12083	20.00		52.65		
		870	14500	17.00		57.54		
	-55*6	390	6500	20.50	1200	33.50	55	YH208M-6V1
		650	10833	18.00		43.65		
		780	13000	16.00		48.55		
	-30*6	270	4500	14.50	1200	17.77	30	YH225M-6V1
		450	7500	12.50		22.53		
		540	9000	11.00		24.89		
ESD-400C	-200*6	840	14000	38.50	1200	145.11	200	YH335L1-6V1
		1400	23333	36.00		173.25		
		1680	28000	33.00		183.06		
	-160*6	810	13500	31.50	1200	99.26	160	YH315M4-6V1
		1350	22500	26.00		116.57		
		1620	27000	21.50		123.18		
	-132*6	750	12500	28.00	1200	82.88	132	YH315L2-6V1
		1250	20833	24.00		102.12		
		1500	25000	20.00		107.50		
	-132*6	660	11000	25.50	1200	68.41	110	YH315L1-6V1
		1100	18333	22.00		82.38		
		1320	22000	19.00		87.56		
	-75*6	600	10000	20.00	1200	53.57	75	YH315S-6V1
		1000	16667	16.00		57.33		
		1200	20000	13.00		59.84		

● THE CURVE OF CAPABILITY

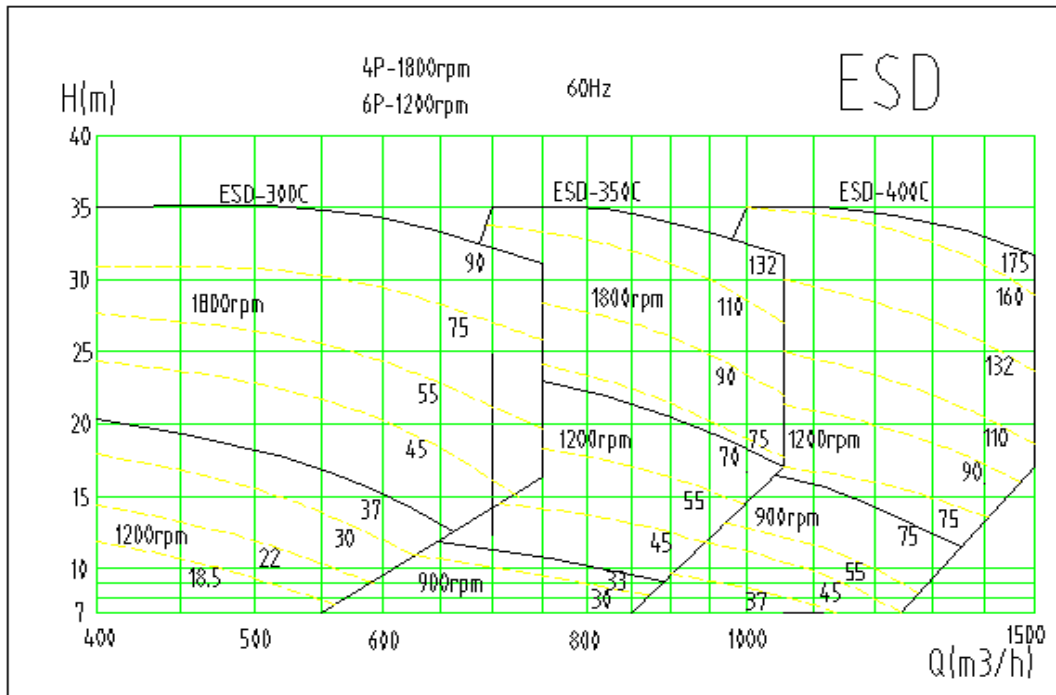

● DIMENSION

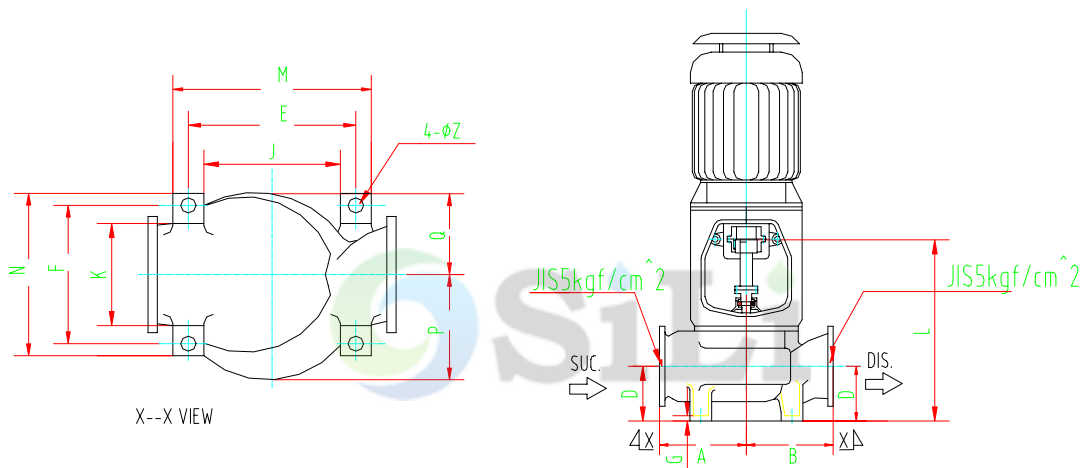

TYPE	SUC	DIS	A	B	C	D	E	F	G	J	K	L	M	N	P	Q	Z
ESD-300C	300	300	400	400	260	260	540	460	25	440	340	1210	640	540	365	270	28
ESD-350C	350	350	500	520	290	290	600	600	30	480	440	1495	720	680	380	340	35
ESD-400C	400	400	550	550	300	300	640	640	30	520	480	1460	760	720	490	360	35